

## Double up #1: (50 Unit Automated Rapid-Exit)



### Dairy Statistics

- Farm location: Gippsland
- Max. cows milked: 450
- Calving pattern: Autumn and spring
- Dairy type: Herringbone Double-up
- No. of units: 50
- Labour units employed: 2



### Automation options

- ACR's
- Out of parlour teat spray
- Automatic drafting
- Rapid exit
- Electronic cow identification
- Milk metering
- Auto plant cleaning
- Auto vat cleaning
- Auto heat detection
- Integrated herd management software



### Dairy Performance

The following performance figures were calculated at peak lactation using CowTime's Milking Monitor:

- 90 Cows per operator per hour (cups on cups off)
- 1200 Litres per operator per hour (cups on cups off)
- 960 Litres per operator per hour (total milk harvesting time)



### Dairy Builder

- Shed design: PHA Australia Ltd
- Phone: 0407 343 917



### Special or key features of this dairy

- This dairy has a sophisticated yard layout that enables many groups of cows to be handled at once but kept separate.
- The cows enter the yards from the rear.
- The wide pit is tapered allowing a good view of cows on the platform.
- The rapid exit system facilitates quick and smooth flow of cows through the dairy.
- The building is large and has a high ceiling making it a cool place to work during the summer.
- Lighting is excellent.
- The pit and milk room are on the same level making access between the two easy and safe.

Disclaimer: "CowTime Dairy Designs has been published for your information only. It is published with due care and attention to accuracy, but CowTime, its funders and representatives accept no liability if, for any reason, the information is inaccurate, incomplete or out of date. The information is a guide only and professional advice should be sought regarding the reader's specific circumstances."

## Double up #2: (50 Unit Automated Rapid-Exit)

1. Yard Entrance  
(from track looking into yard)



4. Dairy layout / cow entry  
(looking from yard into dairy)



2. Holding yards  
(from end looking toward dairy)



5. Inside Pit  
(from holding yard end)



3. Holding yards  
(from dairy looking towards rear)



6. Cow exit  
(from outside shed looking into dairy exit)



Disclaimer: "CowTime Dairy Designs has been published for your information only. It is published with due care and attention to accuracy, but CowTime, its funders and representatives accept no liability if, for any reason, the information is inaccurate, incomplete or out of date. The information is a guide only and professional advice should be sought regarding the reader's specific circumstances."



# CowTime Dairy Designs



## Double up #1: (50 Unit Automated Rapid-Exit)

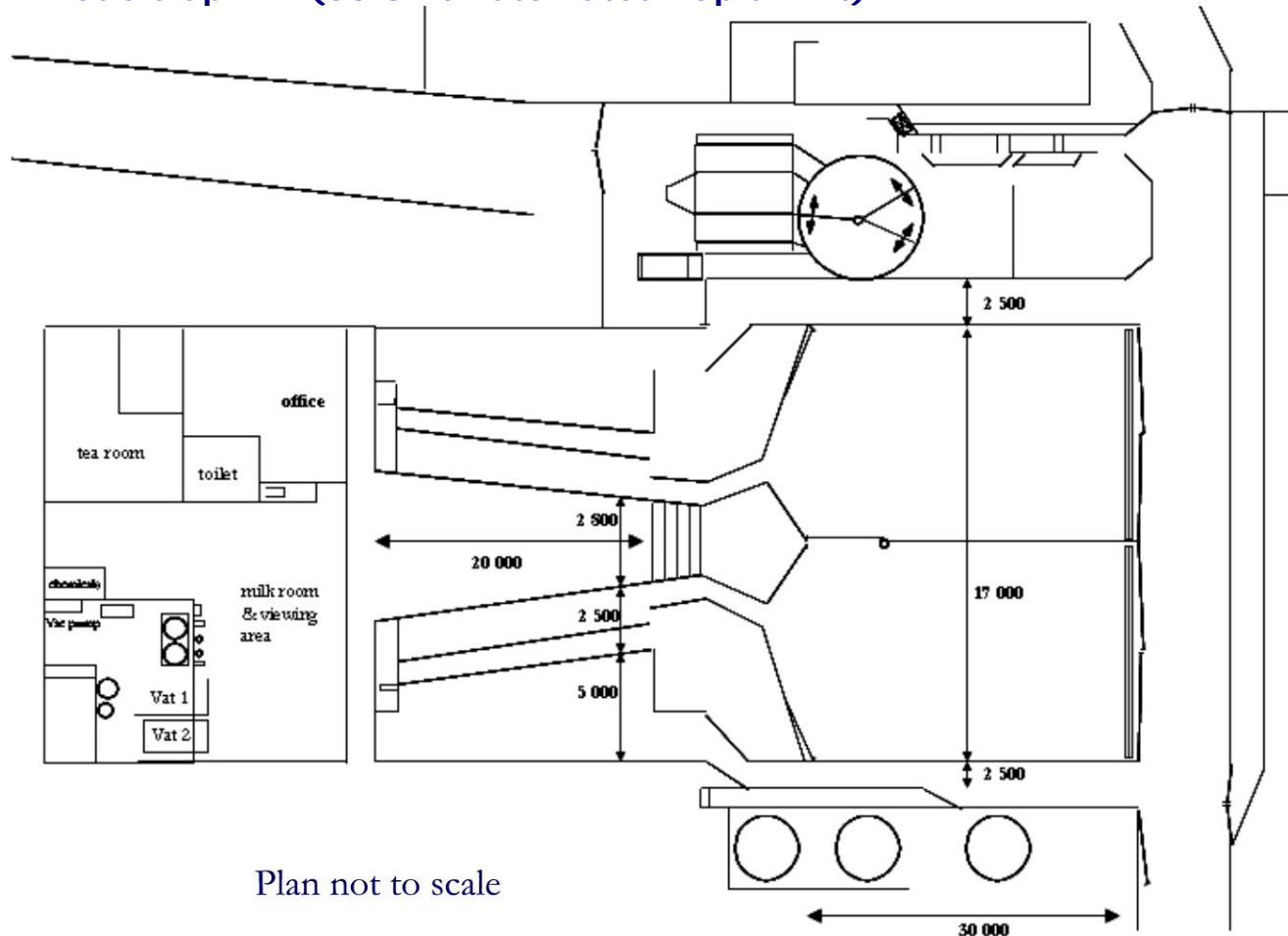

Disclaimer: "CowTime Dairy Designs has been published for your information only. It is published with due care and attention to accuracy, but CowTime, its funders and representatives accept no liability if, for any reason, the information is inaccurate, incomplete or out of date. The information is a guide only and professional advice should be sought regarding the reader's specific circumstances."